



CLK Series Air Chain Hoist



Industry-leading durability, precision, and flexibility

Ingersoll Rand, the most trusted name for quality, high-value hoists, introduces the CLK Series, including 125-, 250- and 500-kilogram models.

The CLK Series is the smart choice for:

- ▶ Durability that delivers more uptime — With a FEM/ISO mechanism classification of 1Am/M4 (ASME HST-5 rating of A5), CLK Series hoists are duty-rated to go an incredible 800 full-load hours between overhauls.
- ▶ Flexibility that lets you get more jobs done — Patent-pending top hook operates with full 360-degree swivel motion or converts quickly to lock in 90-degree increments with no additional parts to buy.
- ▶ Lifting speed and precision control for enhanced ease of use — Lifting speed of 43 fpm (13.1m/min) for the 125 kg models and 32 fpm (9.8m/min) for the 250 kg models is the **best in its class**. Enhanced load “positioning” capabilities and an outstanding combination of motor control and brake release make this hoist ideal for precision applications.
- ▶ “Best-in-the-industry” quiet operation enhances safety and decreases operator fatigue — Sound levels of just 75 dBA make CLK Series hoists easy on operators, while also minimizing the overall ambient noise of the work site.
- ▶ Highly efficient air motor saves money — For hoists in its class, CLK Series gets the most performance from your compressed air output. The CLK Series consumes only 32 cfm (0.9 m³/min) of air lifting rated load and less than 16 cfm (0.5 m³/min) while lowering load.

For more information on how the CLK Series hoists can generate high return on your equipment investment:

See your local distributor

Call 866-207-6923

Visit ingersollrandproducts.com

▶ HOW TO ORDER

Specify hoist by complete model number code as illustrated below. Specify accessories separately by part number. Note that 0 is a number, not a letter, in model part numbers.

Example: CL250K-2C10-C6U-E

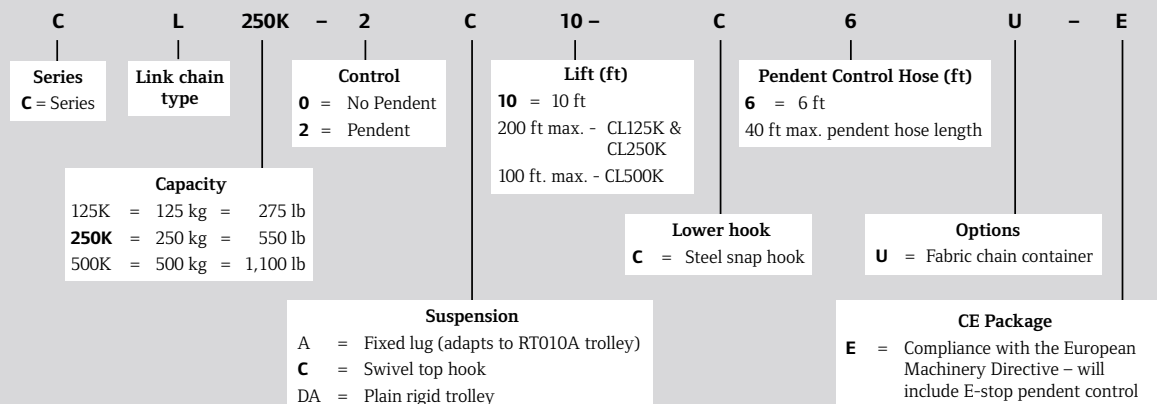

CLK Series

Pneumatic hoists: 125-, 250-, and 500-kg models

Disc brake is non-asbestos and spring-engaged with an air release that offers significant control while minimizing air consumption.

A two-stage differential transmission multiplies motor torque and reduces speed. Oil lubrication helps create maximum durability. Gearing components are made from high-strength, heat-treated steel alloy.

Forged five-pocket pocket wheel provides for smooth lifts and enhanced chain life.

Specially designed slack chain opening prevents dangerous cross-linking by guiding chain to the drive wheels.

Upper and lower limit stops prevent dangerous over-travel of the hook in either direction, reducing possible damage to hoist and load.

100% duty cycle multi-vane (6) air motor offers a high-torque and low-maintenance design. Air porting under the vanes creates smooth operation, positive starting, and long life.

Double reeving is used on 500-kilogram units only.

Bottom latch-type swivel hooks meet OSHA requirements and are supported by anti-friction needle type thrust bearings.

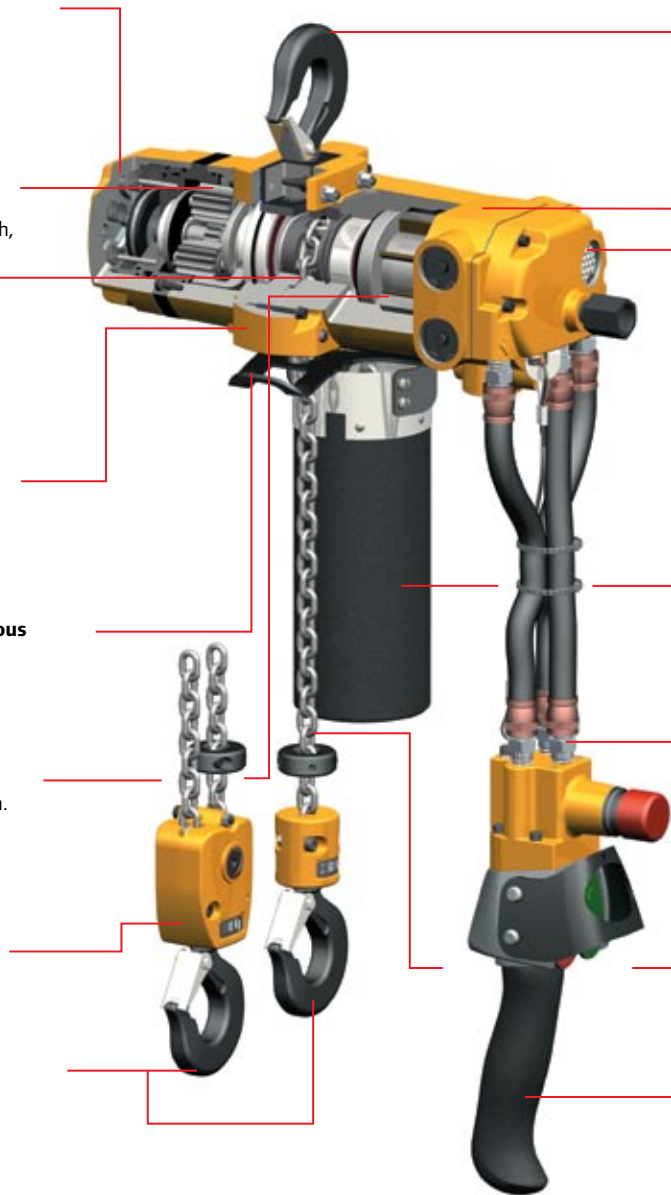

Patent-pending fixed OR swivel-top hook creates unrivaled versatility. Unit is shipped with hook in swivel mode but can be easily converted to fixed position with 90-degree increments. Meets OSHA requirements.

High-strength aluminum housing for maximum portability and weather resistance. Strong yet lightweight with a durable powder-coated finish.

Internal muffler reduces sound levels to a best-in-the-industry 75 dBA.

Optional fabric chain container (available at extra cost) helps keep slack chain out of the way.

Full flow pendant for maximum control and enhanced load positioning capabilities.

Standard link load chain is zinc-plated steel DAT grade 80.

Ergonomic pendant handle (shown with optional E-stop) is rugged and durable. Guard covers both levers and can be used with or without gloves. Optional E-stop (available at extra cost) makes this hoist CE-compliant.

CLK Series

Pneumatic hoists: 125-, 250-, and 500-kg models

CLK Series Specifications

Model	Capacity		# Falls	Hook Mount Headroom		Trolley Mount Headroom		Lifting Speed				Lowering Speed				Chain Size	Chain Weight (per foot of lift)		Net Weight w/10 ft of Lift	
	lb	kg		in	mm	in	mm	Rated Load	No Load	Rated Load	No Load	Rated Load	No Load	Rated Load	No Load		lb	kg	lb	kg
CL125K	275	125	1	11.5	292.1	14.1	358.1	43	13.1	56	17.1	37	11.3	27	8.2	4 x 12	0.24	0.11	34	15.4
CL250K	550	250	1	11.5	292.1	14.1	358.1	32	9.8	56	17.1	45	13.7	27	8.2	4 x 12	0.24	0.11	34	15.4
CL500K	1100	500	2	12.75	323.9	15.35	389.9	15	4.6	26	7.9	22	6.7	13	4.0	4 x 12	0.48	0.22	38	17.2

Working pressure from 5 to 7 bar (70 to 100 psi). Air consumption @ rated load — all models 0.9 m (32 cfm). Air inlet 3/8" NPT. Sound level 75 dBA.

CL125K and CL250K

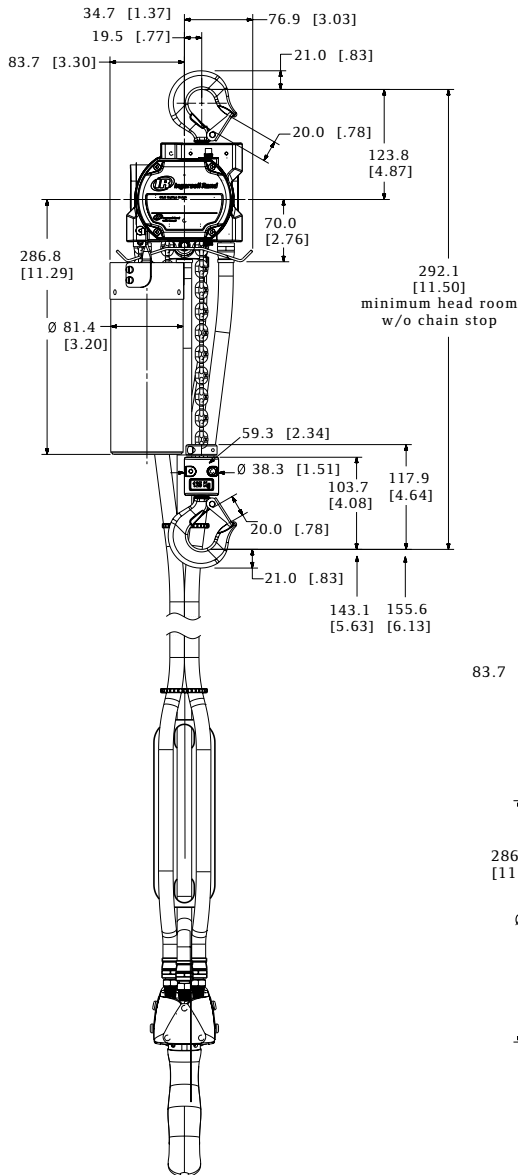

CL125K and CL250K

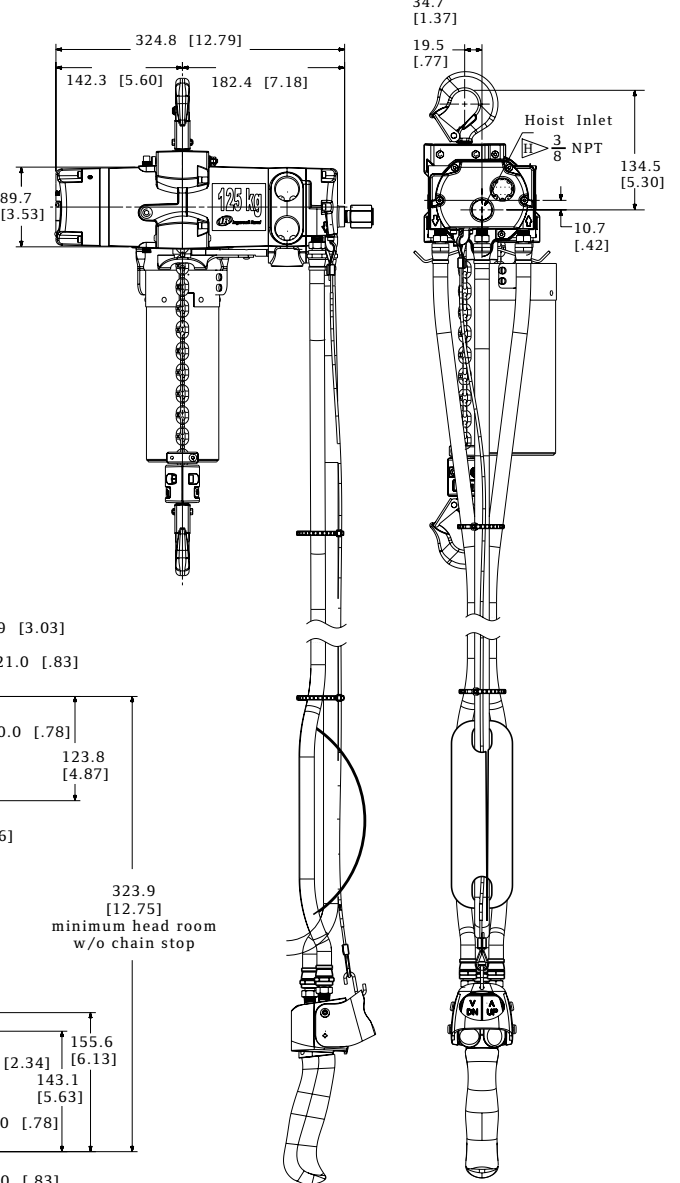

CL500K

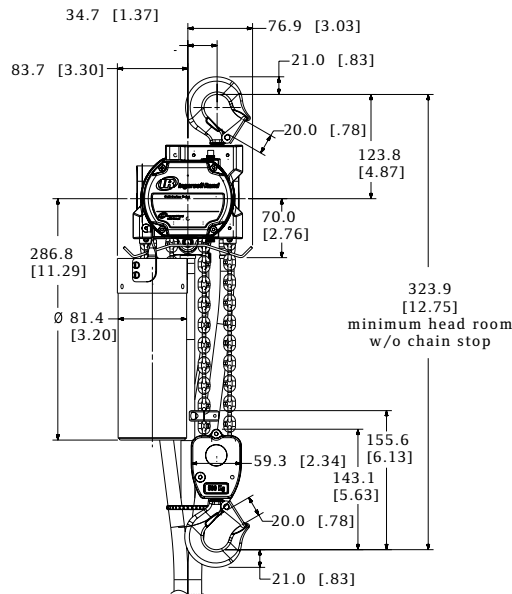

Accessories

Pneumatic hoists: 125-, 250-, and 500-kg models

PT Series Hook-on Trolley

Model	Capacity lb	Capacity metric tons	Flange Adjustment in	Min. Beam Height in	Min. Curve Radius in	Weight lb	Kit no. (order separate)	Flange Adjustment in	Weight lb
STANDARD SERIES									
PT005-8	1,100	0.50	2.6 - 8	4	36	19.7	PT005-WFK	8 - 13	5.5

Wheels are cast iron and the universal tread fits either flat or tapered beams.



Cousin to the PT Series trolley, the twin suspension shaft RT Series trolley offers a rigid connection for the CLK Series of air chain hoists. A lug adapter is required for use.

RT010 Series Trolley

Trolley Part Number	Capacity metric tons	Fits Beam Flange Width in	Minimum Turning Radius in
RT010	0.25 - 1	2.7 - 6	36

Wheels have universal tread for use on flat or tapered beams.



Filters - Regulators - Lubricators

Part No.	Size (in) NPTF	Flow Rate scfm	Adj. Pressure Range psig	Bowl Capacity oz	Height x Width in
TRIO UNITS: FILTERS, REGULATORS, LUBRICATORS					
C38341-810	1/2	150	5 - 250	4	6 x 8.7
C38451-810	3/4	200	5 - 250	4	8.6 x 11.1
C38461-810	1	215	5 - 250	4	8.6 x 11.1



Quick Exhaust Valves

Part Number	For Use With	Control Type	Style	Pendent Length ft
MR-939	All CLK Series	Full-flow	3/8" NPT	15 - 40

The first pair of full-flow valves will be installed between 7 and 8 ft from the pendent handle after pendent hose length reaches 16 ft. Any additional valves will equally divide the remaining hose length.

E-Stop Pendent Handle

Part Number	Description
45667359	Pendent handle assembly with E-stop function



Link Chain Canvas Basket

Part No.	Capacity ft
CL250K-749-20	20
CL250K-749-40	40

Link Chain Canvas Basket



Ingersoll Rand extends through offices and distributors in cities around the world.
Contact the nearest Ingersoll Rand office or write to: Ingersoll Rand, P.O. Box 970 Annandale, NJ 08801 USA.

United States regional sales offices

Tech support, order entry and order status:

Ingersoll Rand Customer Care

510 Hester Drive, P.O. Box 618, White House, TN 37188
Phone: 866-207-6923
or 800-IR-Hoist
Fax: 615-285-0802

International

Ingersoll Rand Canada Inc.

51 Worcester Road, Toronto, Ontario M9W 4K2
Phone: 877-924-7435
Fax: 416-213-4510
Order Desk: 877-924-7435
Fax: 416-213-4506
888-422-2258 (Toll free)

Europe, Middle East and Africa

Ingersoll Rand Winch and Hoist Solutions

Douai Operations

529, Avenue Roger Salengro,
59450 SIN LE NOBLE, France
Phone: 33-3-27-93-08-08
Fax: 33-3-27-93-08-19
E-mail: dou_irep@eu.irco.com

México

Ingersoll Rand S.A. de C.V.
Boulevard Centro Industrial No. 11
Industrial Puente de Vigas
54070 Tlalnepantla, Estado de México
Phone: 52 (55) 85 03 66 00 ext. 6685 & 6686
Fax: 52 (55) 55 65 30 72

Brazil

Alameda Caiapós 311
Tamboré - Barueri - São Paulo - Brazil 06460-110
Phone: 55-11-2109 . 8950
Fax: 55-11-2109 . 8998

Australia Ingersoll Rand Ltd.

Landmark Corporate Centre

45-47 Ventura Place
Dandenong South, Victoria 3175, Australia
Phone: 61-3-8787-4300
Fax: 61-3-8787-5510

Ingersoll Rand India

Ingersoll Rand Wadco Tools Pvt Ltd.

19, Chetak Apartments, Sheth Motisha Lane (Love Lane)
Mazagon, Mumbai 400010 India
Phone: 91-22-2370-4972/3/4/5
Fax: 91-22-2373-2326

Ingersoll Rand SEA Pte. Ltd.

42 Benoi Road, Jurong, Singapore 629903
Phone: 65-6861-1555
Fax: 65-6862-1373

China Ingersoll Rand Co.

10/E, Tower B, City Center of Shanghai,
No.100 Zun Yi Road,
Shanghai, 200051, P.R.C.
Phone: 86-21-5452 9898
Fax: 86-21-5410 1110

WARNING: This equipment is not designed for transporting people or lifting loads above people. It is the user's responsibility to determine the suitability of this product for any particular use and to check compliance with applicable regulations. Before installation, see maintenance and operations manual for additional warnings and precautions.

**Call 866-207-6923 for the distributor locations.
Visit our website, ingersollrandproducts.com.**

© 2010 Ingersoll-Rand Company

Authorized Distributor:



Ingersoll Rand Industrial Technologies provides products, services and solutions that enhance our customers' energy efficiency, productivity and operations. Our diverse and innovative products range from complete compressed air systems, tools and pumps to material and fluid handling systems and environmentally friendly microturbines. We also enhance productivity through solutions created by Club Car®, the global leader in golf and utility vehicles for businesses and individuals.

ingersollrandproducts.com